

Digital Loudspeaker Cross-over Platform Datasheet

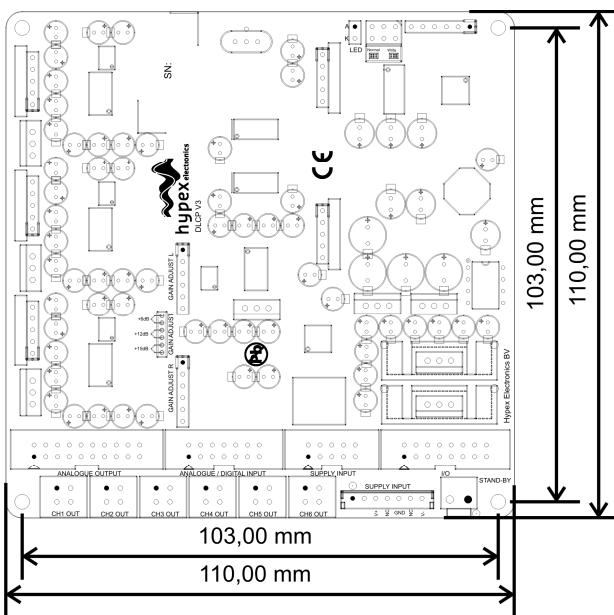
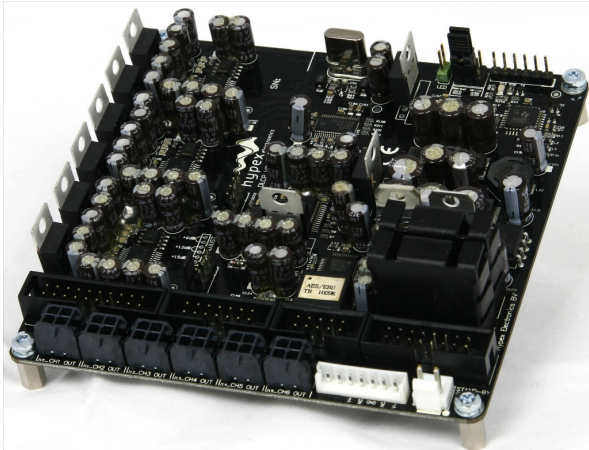

Description

The "DLCP" is a complete hardware/firmware platform for digitally filtered (6 channels) and corrected active multiway loudspeakers. Digital response correction allows significant extra degrees of freedom in the acoustic design of a loudspeaker. Driver parameters can be selected for best efficiency and distortion instead of electrical damping, and the cabinet can now be fully optimized for radiation pattern. For further information, please read the manual (in progress).

Highlights

- Fully user customized filtering
- Great audio performance
- Field updatable firmware
- Current-mode serial I/F
- USB audio
- Compact: 110mm x110mm x30mm
- Low weight: 140gr.

Features

- Compact design
- Personal Computer controlled
- Input sample rates up to 192kHz
- Analogue and digital inputs
- Digital balanced audio loop-through
- Low-jitter discrete clock oscillator
- Balanced audio in and out
- Six channel active filtering
- Fully user-configurable filters
- Firmware updateable by USB
- Separate Clock and Data Paths
- Six user configurable analogue balanced outputs
- High-Level outputs permit direct interface with NC400 / buffered UcD™ ST and HG power amplifiers
- Analogue input gain trim
- 9 local regulators
- IIR filtering
- 96kHz processor sampling rate
- Stand-by mode
- On board Molex Microfit output connectors
- Connector for external LED.
- Optional control board with IR receiver for IR remote control, LCD display and buttons
- Link communication (only with two or more modules and in combination with a controller)

Applications

- High-end consumer audio
- Digital pre amplifier
- Active speakers up to six-way
- Three-way stereo active system
- PA systems
- Studio monitors

Contents

1	Block diagram	3
2	Performance data	4
3	Recommended Operating Conditions	4
4	Connections	5
5	Pin characteristics	9
6	Typical Performance Graphs	11
7	Dimensions	13
8	Revision History	14

1 Block diagram

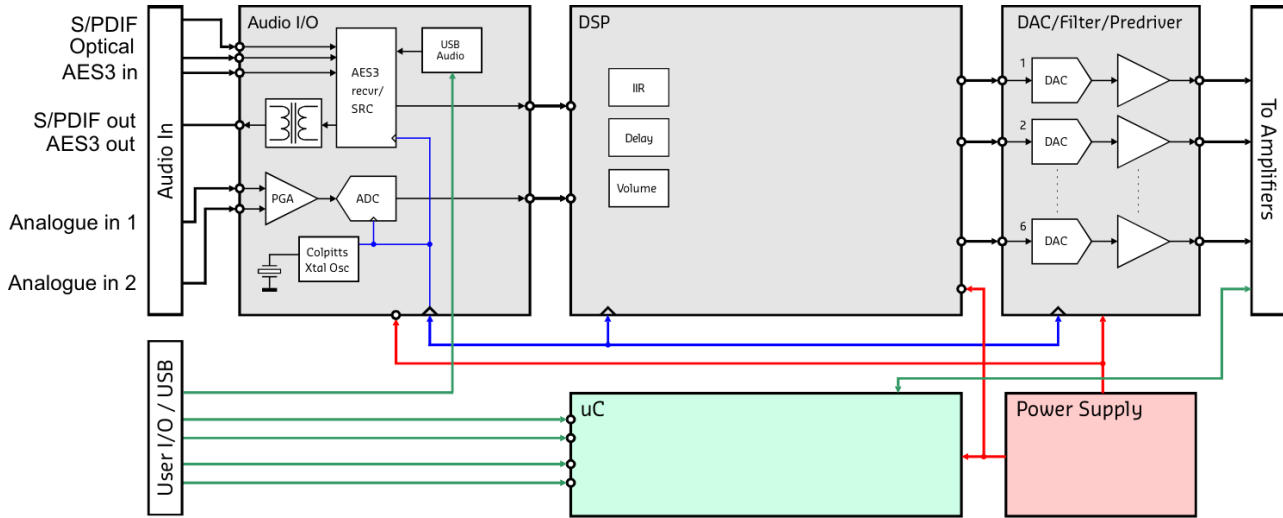

2 Performance data

MBW=20kHz (20Hz-20Khz), unweighted, all filters set to unity, gain adjust 0dB unless otherwise noted

Item	Symbol	Min	Typ	Max	Unit	Notes
Input level ¹⁾	V_{IN}		24.25		dBu	Gain adjust 0dB
			17.95			Gain adjust +6dB
			12			Gain adjust +12dB
			9			Gain adjust +15dB
Output level	V_{OUT}		2.59		V	0 dBFS
Signal/Noise ratio	SNR		113		dB	Digital in
			110		dB	Analogue in
Total harmonic distortion + noise	THD+N		-102		dB	Digital in, -1dBFS
			-102		dB	Analogue in, -1dBFS
Output noise digital	U_N		5,8		uV	20Hz-20kHz
Output noise analogue			7,4			
DM Input Impedance	$Z_{IN,DM}$		44		k Ω	Differential mode
CM Input Impedance	$Z_{IN,CM}$		2.2		M Ω	Common mode
Output Impedance	Z_{OUT}		100		Ω	
Frequency Response (relative to 1kHz)		0		35	kHz	+/- 0.1dB
		-0.2		0.1	dB	DC-0.45fs or 42kHz (whichever is lowest)
DSP sampling rate	F_s		93.75		kHz	
ADC sampling rate	F_s		93.75		kHz	
Supported digital sampling rates	F_s	32, 44.1, 48, 88.2, 96, 192			kHz	All input rates converted to 93.75kHz
Delay per channel		0	0	10	mS	Set in software
CM Rejection Ratio	CMRR		70		dB	All frequencies (gain adjust +15)
Channel separation			>108		dB	Left/Right and interchannel separation
Analogue latency			750		μ S	
Digital latency			1.85		ms	96kHz input sample rate
Standby Current	I_{STBY}		30		mA	

Note 1: See J5/J8 in Connections.

3 Recommended Operating Conditions

Item	Symbol	Min	Typ	Max	Unit	Notes
Supply voltage		15.5 ¹⁾	18	26 ²⁾	Vdc	Positive and negative supply voltage

Note 1: Unit shuts down when the positive rail drops below 15V.

Note 2: Especially on high supply voltages; make sure there's enough airflow to cool the regulators.

4 Connections

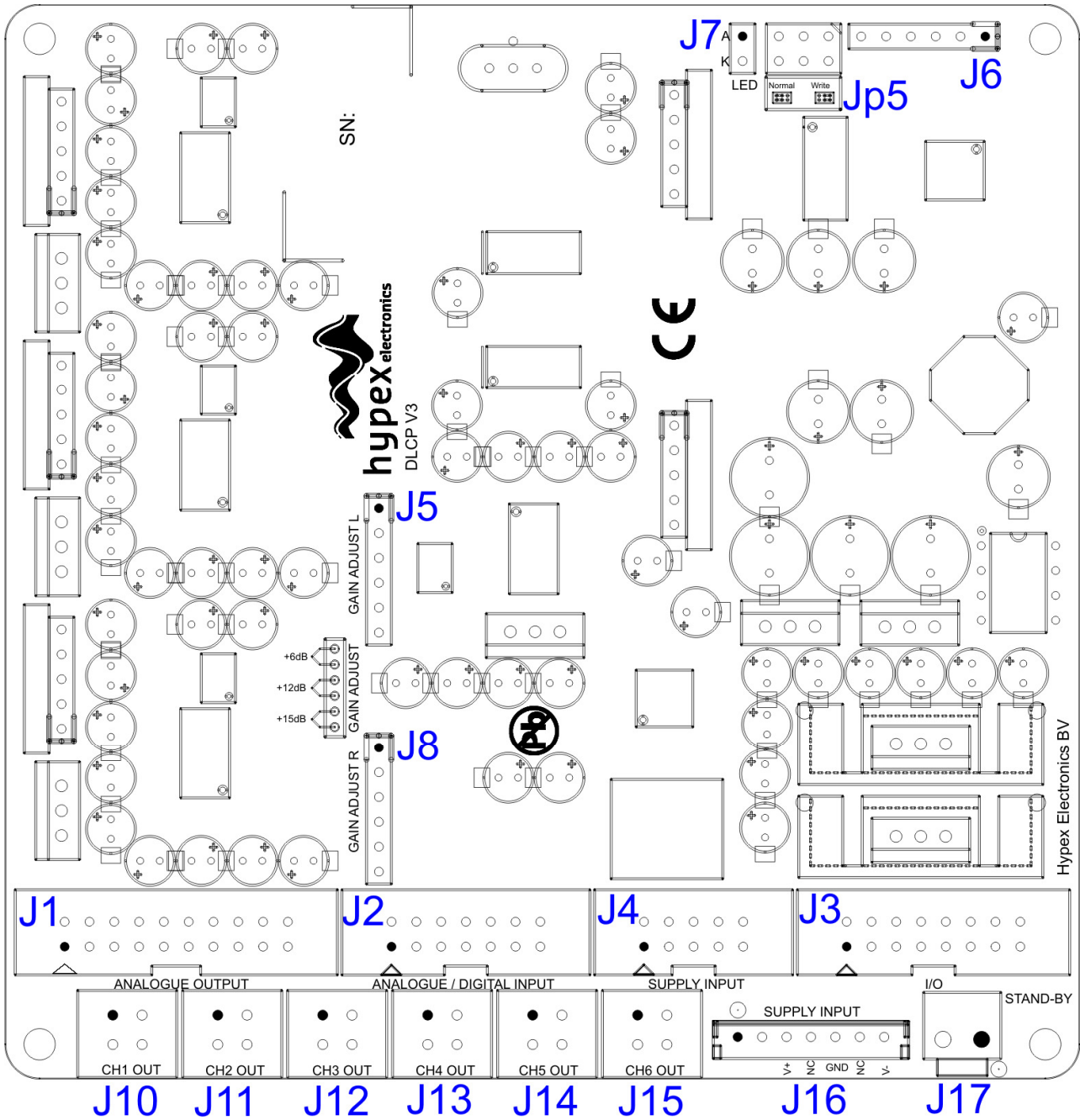

Overview of the connectors on the DLCP

Name	Function
J1	Analogue audio output header (contains all audio outputs from J10-J15)
J2	Analogue/Digital audio in and digital output header
J3	I/O connector (USB, Relay, Control)
J4	Power supply connector (Do not use when a Hypex SMPS module is connected with J16)
J5	Gain adjust header analogue left input
J8	Gain adjust header analogue right input
J17	Standby supply connector
J10	Analogue audio output ch1
J11	Analogue audio output ch2
J12	Analogue audio output ch3
J13	Analogue audio output ch4
J14	Analogue audio output ch5
J15	Analogue audio output ch6
J16	Power Supply connector Hypex SMPS (Do not use when J4 is connected to another supply)
J7	LED connector
J6	Microcontroller & DSP programmer connector, not used by user
JP5	Jumpers for programming or normal operation, not used by user

4.1 J1: Analogue audio out

Connector type: 2.54mm pitch dual row 10 pin box header

Pin	Type	Function
1	Output	Ch1 positive out
2	Output	Ch1 negative out
3	Output	Ch2 positive out
4	Output	Ch2 negative out
5	-	GND
6	-	GND
7	Output	Ch3 positive out
8	Output	Ch3 negative out
9	Output	Ch4 positive out
10	Output	Ch4 negative out
11	-	GND
12	-	GND
13	Output	Ch5 positive out
14	Output	Ch5 negative out
15	Output	Ch6 positive out
16	Output	Ch6 positive out
17	Output	Amp_enable
18	-	GND
19		N.C.
20		N.C.

4.2 J2: Analogue/digital audio I/O

Connector type: 2.54mm pitch dual row 7 pin box header

Pin	Type	Function
1	Input	Analogue left positive in
2	Input	Analogue left negative in
3	Input	Analogue right positive in
4	Input	Analogue right negative in
5	-	GND
6	-	GND
7	Input	S/PDIF in
8	Output	S/PDIF out
9	Input	AES positive in
10	Input	AES negative in
11	Output	AES positive out
12	Output	AES negative out
13	Input	Optical in
14	-	GND

Please place this filter on your analogue inputs if you don't use the optional DLCP input board;

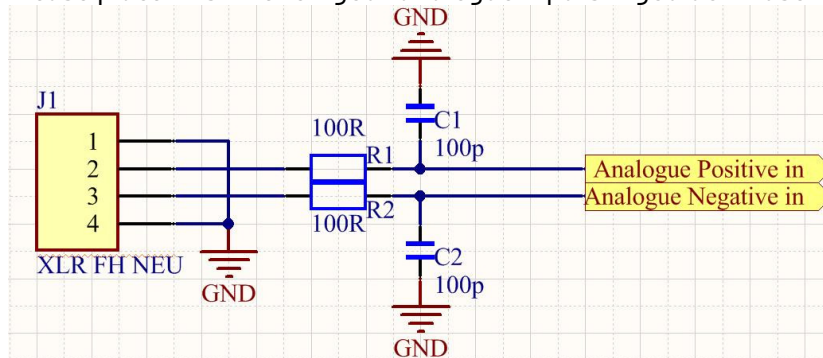

4.3 J3: I/O USB, midi, relay

Connector type: 2.54mm pitch dual row 8 pin box header

Pin	Type	Function
1	Input	Midi in positive
2	Input	Midi in negative
3	Output	Midi positive out
4	Output	Midi negative out
5	In/output	USB data positive
6	In/output	USB data negative
7	Input	USB VCC
8	-	GND
9	Output	Relay supply voltage
10	Output	Relay 1 control
11	Output	Relay 2 control
12	Output	Relay 3 control
13	-	GND
14	Output	Controller board supply voltage (+5V)
15		For future use
16		N.C.

4.4 J7: External LED

Connector type: 2.54mm pitch 2 pin header

Pin	Type	Function
1	Output	Led output (anode)
2	-	GND (cathode)

4.5 J10-J15: Analogue audio out (ch1-ch6)

Connector type: 2x2 pin Molex® Microfit® header type 43045-0412 (see www.molex.com), mates with 43025-0400 cable part.

Pin	Type	Function
1	Output	Ch positive out
2	Output	Ch negative out
3	Output	Amplifier enable
4	-	GND

The audio output is differential. This means that ground is not part of the audio signal. When connecting an unbalanced amplifier, treat pins 1 and 2 as a floating output with pin 2 being the “audio ground” of the amplifier. Pin 4 may be used to attach the shield of a shielded twisted pair cable, but the “audio ground” connection of an unbalanced amplifier should never connect here.

4.6 J16: Hypex SMPS power supply

Connector type JST (www.jst.com) JST-B7B-EHA, mates with JST-EHR-7 cable part.

This connector should not be used when J4 is connected to another power supply.

Pin	Type	Function
1	Output	Supply standby (Electrically connected to pin 1 of J4)
2	Output	Amplifier standby (Electrically connected to pin 2 of J4)
3	Input	Positive input voltage (Electrically connected to pin 3 and 4 of J4)
4		N.C.
5	-	GND
6		N.C.
7	Input	Negative input voltage (Electrically connected to pin 7 and 8 of J4)

4.7 J4: Power Supply

Connector type: 2.54mm pitch dual row 5 pin box header

This connector should not be used when J16 is connected to a Hypex SMPS power supply.

Pin	Type	Function
1	Output	Supply standby (Electrically connected to pin 1 of J16)
2	Input	Amplifier standby (Electrically connected to pin 2 of J16)
3	Input	Positive input voltage (Electrically connected to pin 3 of J16)
4	Input	Positive input voltage (Electrically connected to pin 3 of J16)
5	-	GND
6	Input	Standby voltage (Electrically connected to pin 1 of J17)
7	Input	Negative input voltage (Electrically connected to pin 7 of J16)
8	Input	Negative input voltage (Electrically connected to pin 7 of J16)
9	Input	Amplifier positive supply voltage measurement
10	Input	Amplifier negative supply voltage measurement

4.8 J17: Standby

Connector type JST (www.jst.com) JST- B2P-VH, mates with JST-VHR-2N cable part.

Pin	Type	Function
1	Input	Standby voltage (Electrically connected to pin 6 of J4)
2	-	GND

5 Pin characteristics

5.1 Amp_enable output

This pin is controlled by the microcontroller (open collector). This pin is left floating, when the amplifier should be in standby modus/should be muted, in normal operation it's connected to ground.

5.2 Relay 1,2,3 control output

These pins control the relays on the optional DLCP Inputboard. These are open collector outputs.

Analogue Input select	Relay control outputs	High/Low
Analogue 1	1	High (Open collector)
	2	High (Open collector)
	3	High (Open collector)
Analogue 2	1	Low (Pulled to ground)
	2	High (Open collector)
	3	High (Open collector)
Analogue 3	1	High (Open collector)
	2	High (Open collector)
	3	Low (Pulled to ground)
Analogue 4	1	High (Open collector)
	2	Low (Pulled to ground)
	3	Low (Pulled to ground)

5.3 Amplifier standby

This open collector output pin is controlled by the microcontroller, and is by default pulled up to the standby supply voltage. It's pulled to ground when the amplifiers should be enabled. For more information see datasheet of the Hypex SMPS XXX.

5.4 Supply standby output

This pin is controlled by the microcontroller, and is high when the DLCP is in standby modus. When connected to a Hypex SMPS XXX, see datasheet of the connected SMPS for more information. In order to use this function a standby supply voltage must be present.

5.5 Amplifier positive supply voltage measurement input

This pin can be used to measure the positive amplifier supply voltage, for a limiter, but is not yet implemented in software.

Item	Type	Min	Typ	Max	Unit	Notes
Positive Voltage on J4:9	Input	TBD	TBD	TBD	Vdc	

5.6 Amplifier negative supply voltage measurement input

This pin can be used to measure the negative amplifier supply voltage, for a limiter, but is not yet implemented in software.

Item	Type	Min	Typ	Max	Unit	Notes
Negative Voltage on J4:10	Input	TBD	TBD	TBD	Vdc	

5.7 Relay supply voltage output

Supply voltage for relays on optional DLCP Input PCB.

Item	Type	Min	Typ	Max	Unit	Notes
Voltage on J3:9	Output		5		Vdc	Max. current= 110 mA.

5.8 External LED output

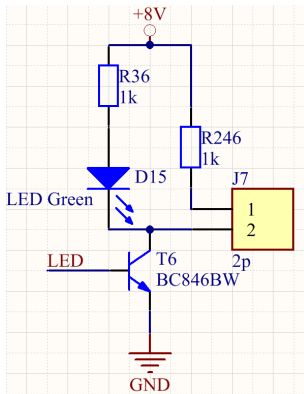

A LED connected to J7 will light up when the DLCP is turned on, and flashes a few times when the supply voltage drops below 15Vdc.

5.9 Controller board supply voltage output

This supply pin is used for the control board.

Item	Type	Min	Typ	Max	Unit	Notes
Voltage on J3:14	Output		5		Vdc	

5.10 Positive input voltage

Item	Type	Min	Typ	Max	Unit	Notes
DC voltage on J4:3 and 4 /J16:3	Input	15.5	18	26	Vdc	
Current ¹⁾	Input	300		390	mA	
Current ¹⁾	Input	380		490	mA	With optional Inputboard and Control.

Note 1: Maximum current value is drawn at min. input supply voltage, min. current value is drawn at max. input supply voltage (because of the DC-DC converters).

5.11 Negative input voltage

Item	Type	Min	Typ	Max	Unit	Notes
DC voltage on J4:7 and 8 /J16:7	Input	15.5	18	26	Vdc	
Current	Input	180		180	mA	

5.12 Standby Input

When you want to use the standby modus of the DLCP, you have to apply an external DC voltage (standby supply) on J17 / J4:6.

Item	Type	Min	Typ	Max	Unit	Notes
DC voltage on J17:1/J4:6	input	6.5	8	12	Vdc	
Current	Input		30	40	mA	

5.13 Chassis grounding

All four mounting holes are connected to ground with a 100nF capacitor. Connect them all to chassis with a metal spacer for optimum EMI performance.

6 Typical Performance Graphs

6.1 Frequency response (Analogue)

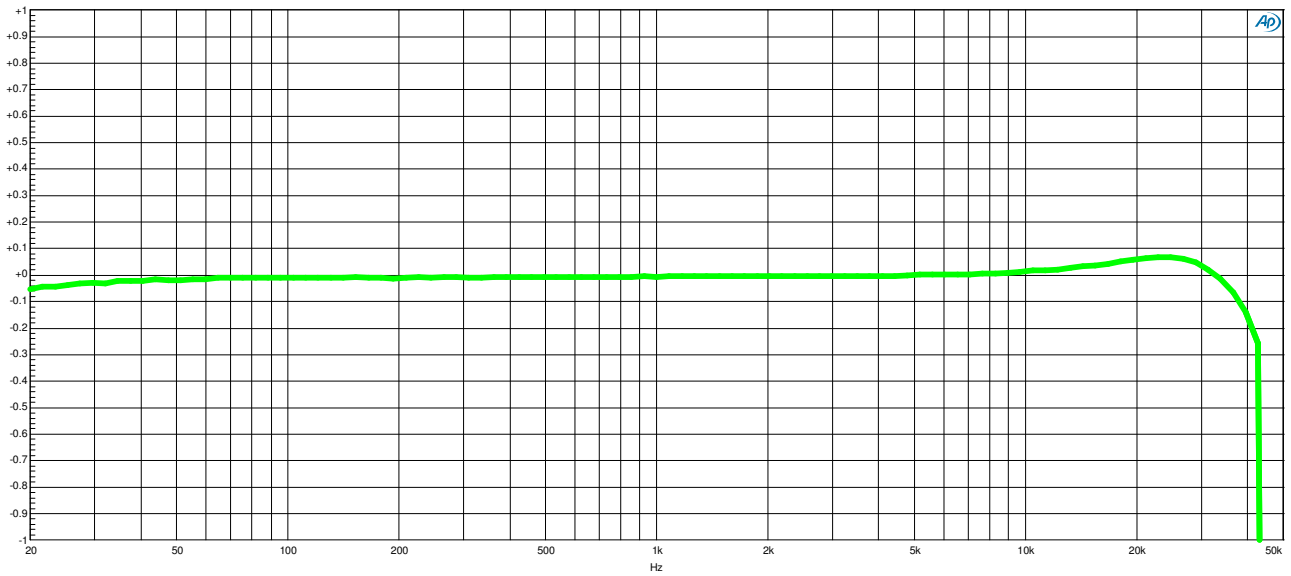

6.2 THD+N vs. input voltage (Analogue, 1Khz)

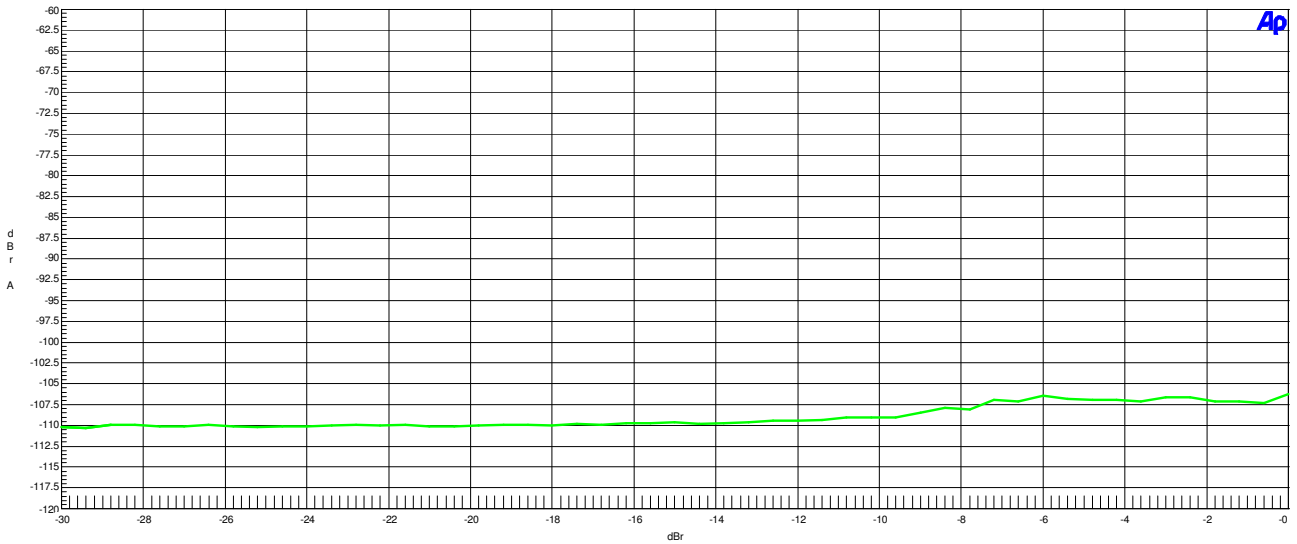

6.3 THD+N vs. Frequency (Analogue in, -1 dBFS)

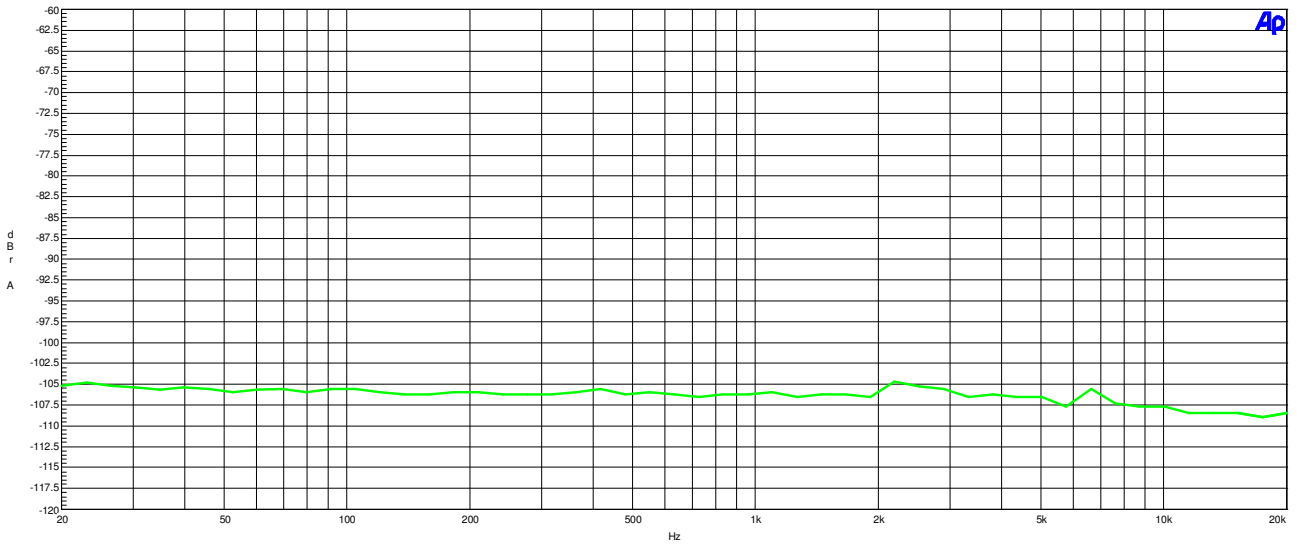

6.4 FFT (Analogue in, -20dBFS, 5kHz)

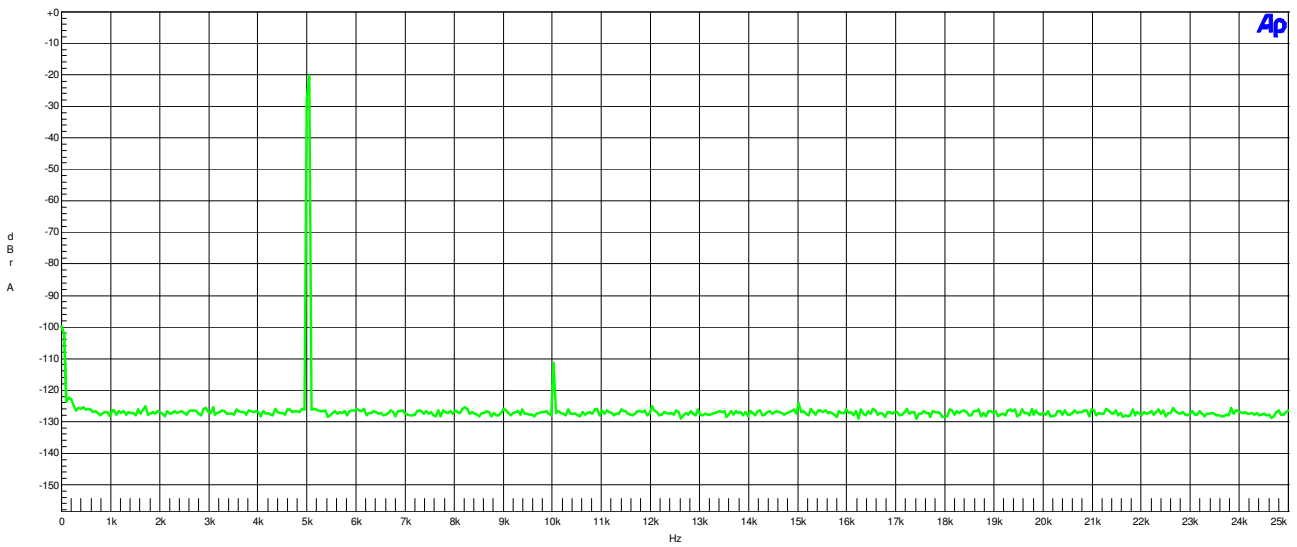

7 Dimensions

Top view

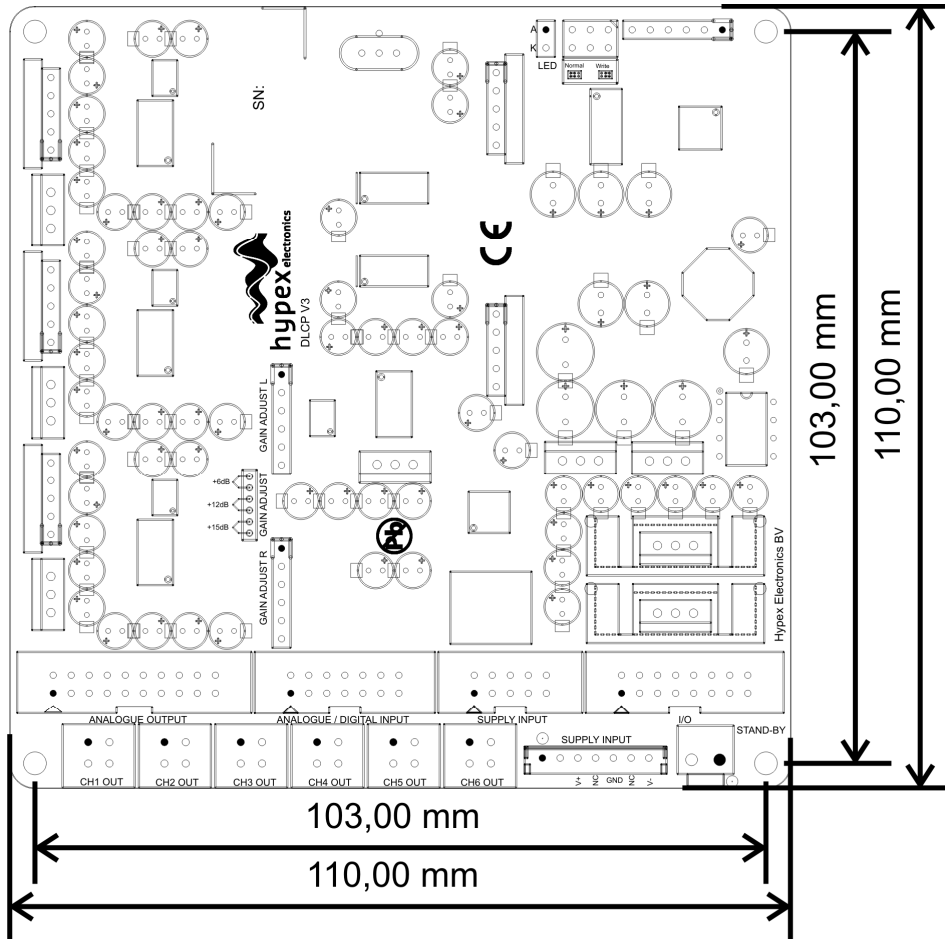

Side view

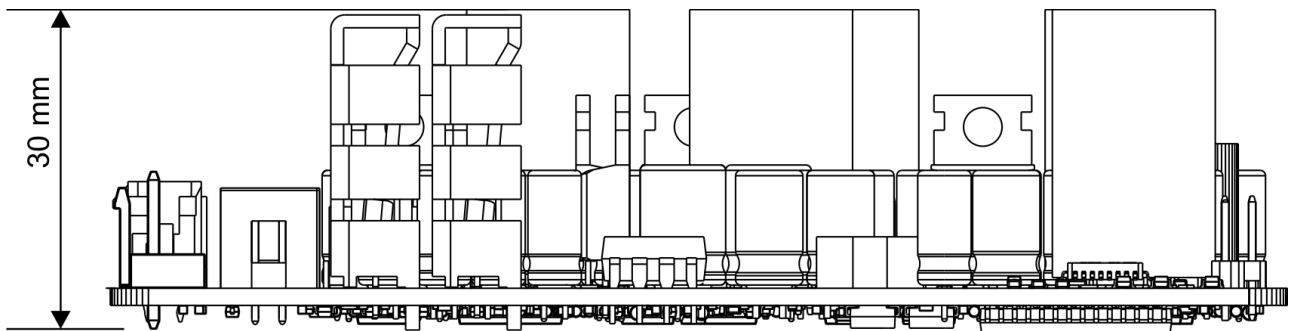

DISCLAIMER: This product is designed for use in sound reproduction equipment in conjunction with Hypex amplifier modules. No representations are made as to fitness for use in other applications. Except where noted otherwise any specifications given pertain to this subassembly only. Responsibility for verifying the performance, safety, reliability and compliance with legal standards of end products using this subassembly falls to the manufacturer of said end product.

LIFE SUPPORT POLICY: Use of Hypex products in life support equipment or equipment whose failure can reasonably be expected to result in injury or death is not permitted except by explicit written consent from Hypex Electronics BV.

Warranty

The work carries warranty out for all provable material and production defects for the duration of 24 months starting from sales. All damage, which is caused by wrong or inappropriate operation, is excluded from the warranty.

8 Revision History

The following table shows the revision history for this document.

Document Revision	PCB Version	Description	Date
R1	DLCP V1	Initial Draft.	23.11.2010
R2	DLCP V3	Updated because of new hardware version	18.12.2012