

miniDSP Kit

USER MANUAL

V1.6



Revision	Description	Date
V1.5	miniDSP PCB revision - Rev1	31-05-2010
V1.6	New miniDSP PCB revision – Rev2	16-12-2010
V1.7	Jumper for RevA & B	26-03-2012



Table of content

1	System setup	3
2	miniDSP Basics	4
2.1	What is a miniDSP?	4
2.2	miniDSP programming	4
2.3	Board connectivity.....	5
Typical connection diagram.....		5
Typical connection diagram.....		6
2.3.1	minDSP DC Power options	6
2.3.2	miniDSP RevA vs RevB	6
3	Typical plug-in architecture.....	8
3.1	Audio settings	8
3.1.1	Inputs and RMS meters (Available in all plug-ins)	8
3.1.2	High and Low pass filters (Available in Mixer, 2way Xover, 4way plugins)	9
3.1.3	Graphic equalizer (Available in Mixer, 2way/4way Xover Graphic EQ version)	10
3.1.4	Parametric Equalizer (Available in 2way PEQ, 4way PEQ versions)	10
3.1.5	Matrix mixer controls (Available in Mixer plug-in only).....	11
3.1.6	Output Controls for Gain, output level, delay and phase (All plug-ins).....	11
3.1.7	Advanced Plug-in features	12
3.1.8	Room EQ Wizard (REW) integration (Advanced software only).....	13
3.2	System settings (Available for all plug-ins).....	14
3.2.1	Load configuration:.....	14
3.2.2	Save configuration.....	14
3.2.3	Restore.....	14



1 System setup

Minimum System Requirements for software installation

MiniDSP controller software runs in a PC environment with the following minimum requirements.

Software

- Microsoft® Windows® Vista® SP1/ XP pro SP2
- Microsoft® .NET framework v3.5
- Adobe AIR environment (latest version)
- Adobe Flash player (latest version)

Hardware

- PC with 1GHz or higher processor clock speed recommended / Intel® Pentium®/Celeron® family, or AMD K6®/AMD Athlon®/AMD Duron® family, or compatible processor recommended.
- 256 megabytes (MB) of RAM or higher recommended
- USB 2.0 port
- Keyboard and mouse or compatible pointing device

Package content

Your miniDSP kit includes:

- 1 x miniDSP 2x4
- 1 x miniUSB cable
- 1 x 3' RCA audio cable
- Step by Step startup guide

Disclaimer / Warning

An incorrect miniDSP configuration could easily damage your audio system. MiniDSP can not be responsible for any damage that may result from the improper use of this product. As with any other product, we do recommend that you carefully read the manual and other technical notes to insure you fully understand how to operate the board.

As a general guideline, you should first configure your miniDSP board **before** connecting anything to the outputs of the MiniDSP 2x4 (loudspeakers/other output sources). Doing so will make sure that you have the software correctly configured and won't cause any damage to your system. Once again, miniDSP can not be responsible of any damages the board make cause to your system.

Finally, MiniDSP is a very flexible board and 99% of typical questions we receive at the tech support department are already answered in this user manual. So please take the time to carefully read this user manual. Thanks for your understanding!



2 miniDSP Basics

Before diving into the details of this board, it is important for you to fully understand what a miniDSP does and how it can be useful to the setup of your audio system. The following section will highlight basic concepts of a miniDSP 2x4.

2.1 What is a miniDSP?

miniDSP is a Digital Audio Signal Processor capable of performing a wide range of applications, from filtering, equalization, muting, time alignment etc... The control of the device is performed from a software application, so called a plug-in, which provides control of the board settings over USB. Only one plug-in can run on a miniDSP board at a time and only one miniDSP board can be controlled at a time.

2.2 miniDSP programming

A good part of the success of the miniDSP concept lies in its simplicity of use. Here are the typical steps required to program a miniDSP.

- Connect the board to your PC/Mac machine
- Launch the plug-in, by default in off-line mode and allowing you to configure settings as required.
- The next step is to "Connect & Synchronize" your PC to the board, i.e. flashing the configuration you just have in your plug-in and going to the On-line mode.
- Once the board synchronized, you will be in what the so called "On-line mode", i.e. able to hear the effect on real time changes to the settings. No further "Synchronization" to the board is required since all settings from now on are saved to both the DSP and the Flash component of the device for long term memory.
- Once happy with your configuration, simply un-plug the board and the audio configuration will run as last modified in on-line mode. No need for a PC connection from now on since the board will boot up every-time with that configuration.

Now that you have a basic understanding of how things work, let's get down to the details.

2.3 Board connectivity

First step in configuring your board is getting familiar with its connectivity.

miniDSP Top View

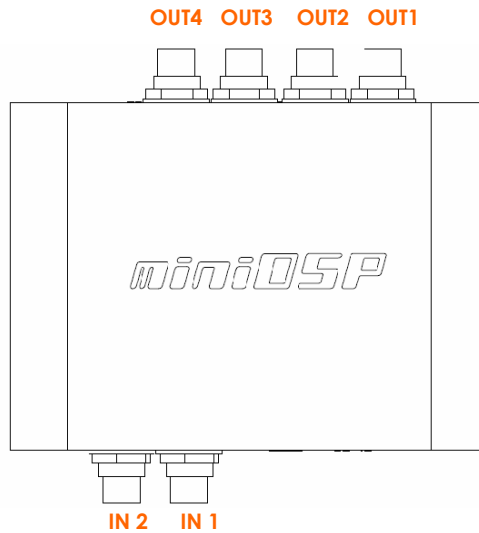

miniDSP Front View

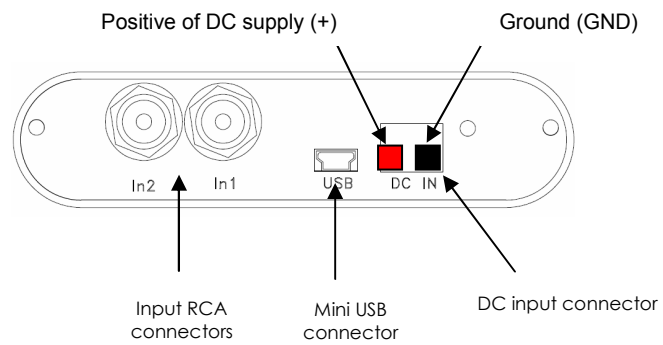

Typical connection diagram

The following diagram is a typical connectivity diagram for a basic setup with analog inputs, analog outputs. Stacked configurations with miniDSP I/O cards such as miniAMP/miniDIGI are shown in later sections of this user manual. To prevent any damage, make sure the board is turned OFF before doing any connection modifications.

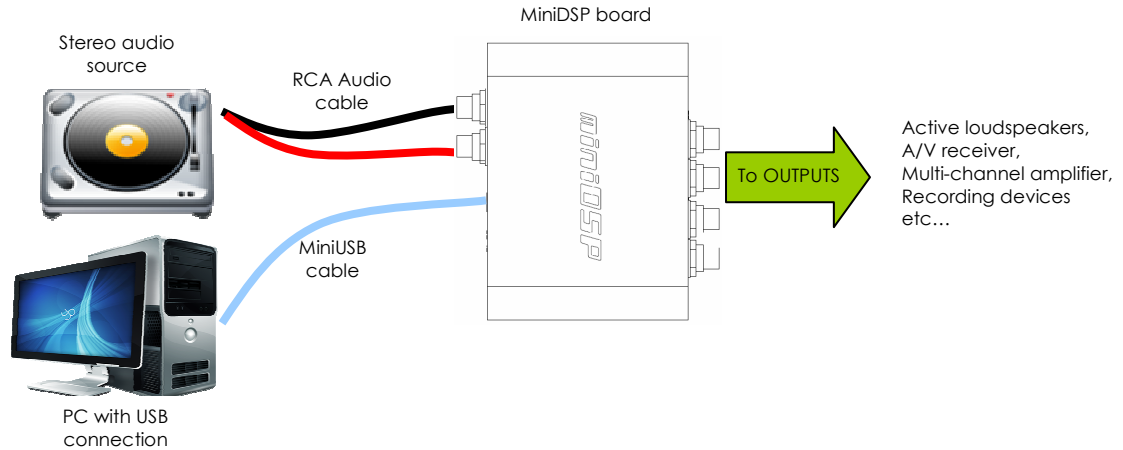

2.3.1 minDSP DC Power options

miniDSP 2x4 may receive power from different configurations:

- Being a USB self powered device, a USB connection to your PC or a standard USB charger supply (150mA @ 5V) is sufficient to power the device. While a quick check from looking at the back of the product will not hurt, 99% of USB chargers will easily handle this small load.
- An external DC supply may also be used to the board using the terminal block connector. Select a power supply with DC voltage between 5 to 24VDC.

Be extremely careful to apply the correct polarity to the Terminal block connector as below.

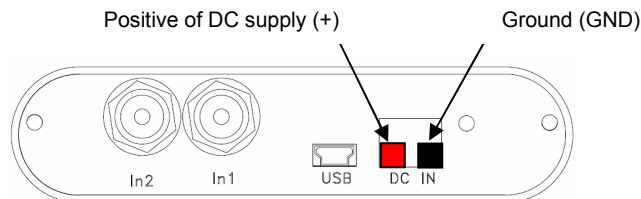

2.3.2 miniDSP RevA vs RevB

miniDSP 2x4 comes in 2 configuration to adjust the maximum input level of the unit. The RevA has a maximum input level of 0.9Vrms while the RevB has a max input level of 2Vrms. If you would like to modify your unit, a simple screwdriver will allow you to open the panels of the unit and access the internal jumpers as shown below.

0.9Vrms Mode

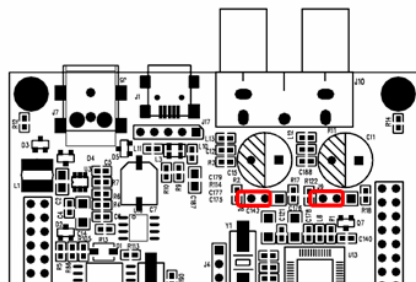

2Vrms Mode

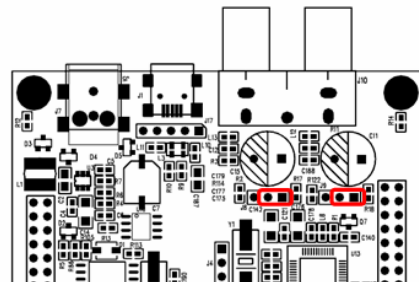

Plug-in configuration

1. Before connecting the MiniDSP board to the PC, you need to install the plug-in software that was downloaded from the plug-in section of our online store. Please refer to the download instructions sent to you by email on the day of shipping of the board.
2. As per the system requirements, the following frameworks need to be installed:
 - Microsoft® .NET framework v3.5 (PC only)
 - Adobe AIR environment (Mac/Win)
 - Latest version of Adobe Flash player (Mac/Win)
3. Once the software installed, connect the MiniDSP board to a USB 2.0 of your PC, using the provided mini USB cable. The device will be recognized as a HID driver and does not require any driver installation.

Note: A blue LED in the center of the board will flash at a rate of 1sec on, 1 sec off once the board is correctly powered.

4. Open the software application to gain control of the board. Please read carefully the following lines:

By default, all plug-ins start in offline mode, meaning changes made on the user interface do not affect your configuration. It is designed in such a way that you can visually confirm your configuration before loading it to the MiniDSP kit.

You should also know that plug-ins can only synchronize from PC to board and are not able to “retrieve” a configuration from the kit. It basically means that if you really like your configuration, make sure you save it somewhere on your hard drive (more to follow below) to be able to reload them at a later time.

5. Once the configuration checked, you can go online by clicking the “Connect & Synchronize” button as shown below.



Providing your board is connected to the PC with a USB cable, the following important dialog box pops up with 4 options:

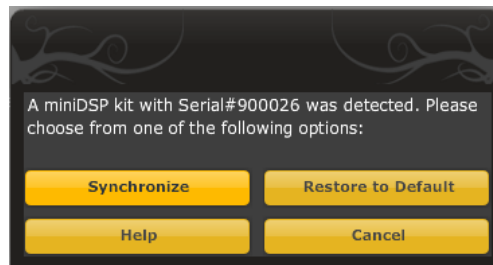

a) Synchronize: With this option, the current plug-in configuration will be loaded/flushed to the MiniDSP kit and your plug-in turned to “On-line” mode. Warning that it will overwrite whatever configuration was previously loaded on the board. If you’d like to load a different configuration, click cancel and go to the settings tab to load one of your previously saved configurations.

Note: If you previously installed a different firmware version on your kit, this button will display: Synchronize & Upgrade. Meaning, the MiniDSP kit firmware will be upgraded to the current plug-in firmware along with the current settings you have.

b) Restore to Default: With this option, the software application resets all settings back to factory default and reload the firmware. Warning that all current settings will be lost and there are no ways to be able to recover them.

c) If in any doubt, click the **Help** button to refresh your memory on these choices or click **Cancel** to be able to go back to the offline mode.

In either synchronization steps, the following dialog box will pop-up. It's very important that you do not un-plug the board in the middle of a firmware upgrades or you may corrupt the configuration.

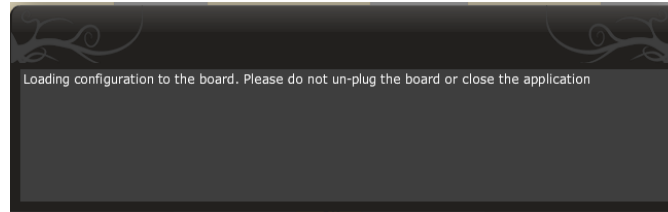

6. Once the board fully synchronized, a “Successful connection to the board” message pops up. From this point on, all changes to the configuration will be real time and live, therefore giving you the chance to hear the effect of your equalization, filtering, tuning...

3 Typical plug-in architecture

Depending on your plug-in, the software is organized as below:

- Main tab: Gives you access to Audio or System settings sections
- Synchronize button: Allows you to go online and gain control of your system
- Audio Mute: Mute all inputs & outputs
- Help link: A quick link to get back to the main help page
- Control toolbar: Click to access controls of each audio algorithm

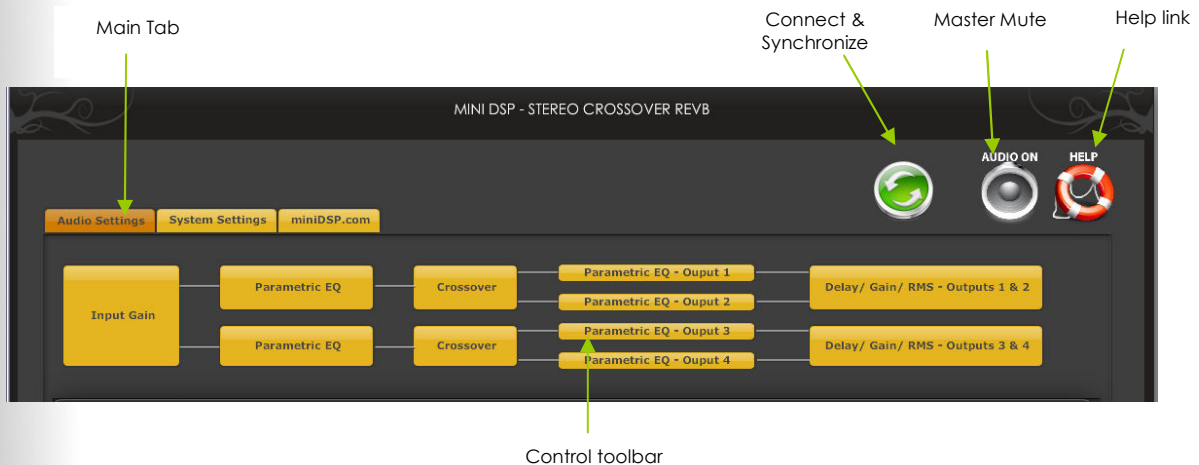

3.1 Audio settings

3.1.1 Inputs and RMS meters (Available in all plug-ins)

The first step in configuring your MiniDSP consists in making sure audio is being fed to the input correctly. To do so, click on the button labeled “inputs”. The RMS meter will quickly indicate the average value of the input signal in dBFS (i.e. relative to the full scale of the ADC or 24bit I2S signal). Individual faders control the digital gain at the input and per channel mute status.

This meter displays dB full scale (dBFS) values and will saturate at 0dBFS for about 0.9Vrms mode or 2Vrms mode. Make sure to keep the signal below 0dBFS (red color) and with enough headroom to prevent distortion.

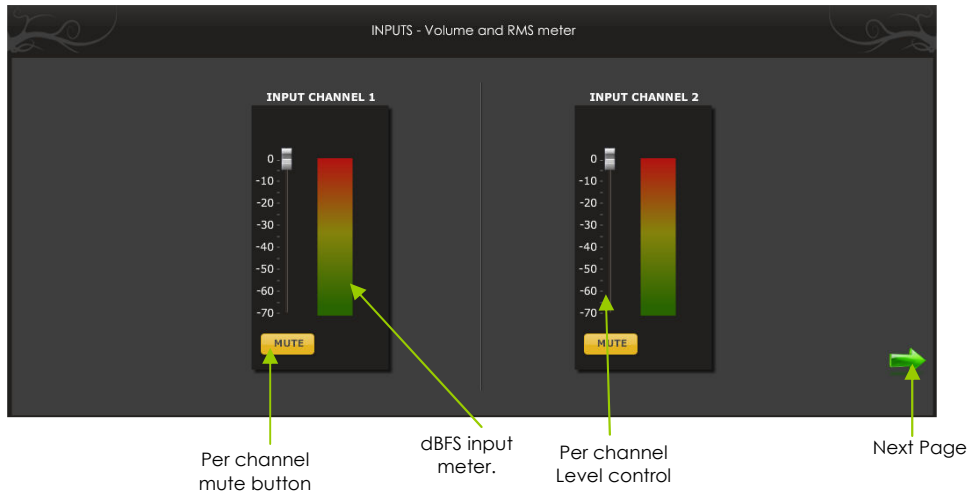

Screenshot of Input window for 4way plug-ins

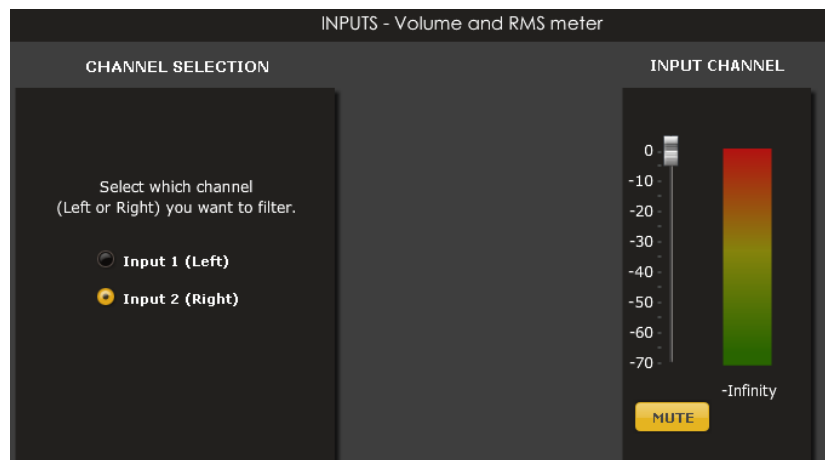

Click the **Next** button to switch windows OR click one of the control toolbar buttons. A darker color indicates the current active tab.

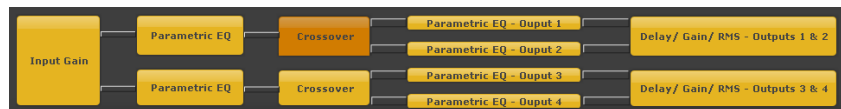

3.1.2 High and Low pass filters (Available in Mixer, 2way Xover, 4way plug-ins)

Controls for the Low and High pass filters are very much similar.

- Cut off frequency: Select the -3dB frequency by either entering the value or using the up & down arrows of the numeric box.
- Choose one of the three filter types:
 - Linkwitz Riley (LR): Available in 12, 24, 48dB/oct
 - Butterworth (BW): Available in 6, 12, 18, 24, 30, 36, 42, 48dB/oct
 - Bessel: Available in 12dB/oct

Each filter has different phase and amplitude characteristics. We recommend you to look online for more information about the specifics of each filter.

- Bypass button allows you to disable the filter (Enabled by default). Make sure to bypass the filter if you do not need a low pass filter.

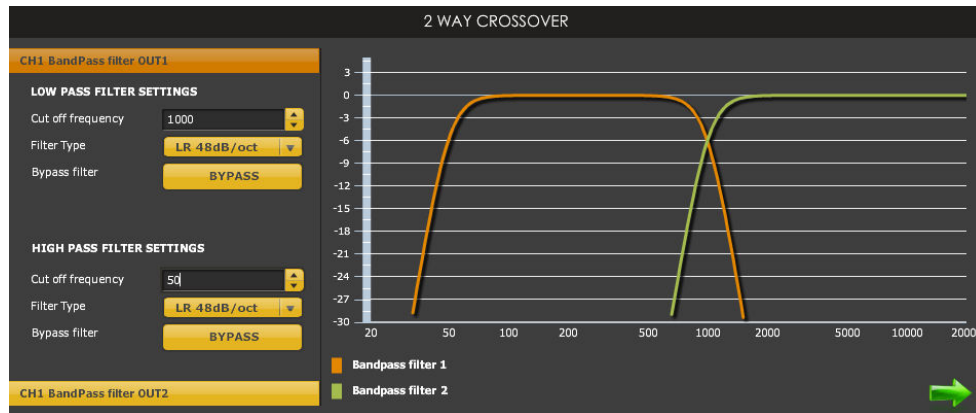

The log scale graph gives you the equivalent response of the applied filter. By pointing the mouse anywhere on the plotted curve, the dB attenuation and respective frequency are displayed.

3.1.3 Graphic equalizer (Available in Mixer, 2way/4way Xover Graphic EQ version)

- Bypass: Disables the equalization but doesn't reset the settings. A handy tool to check the influence of equalization on your system without resetting to zero
- Reset: Sets all boost faders back to zero
- Link channels: If enabled, any change on either graphic EQ channels is reflected on both graphic EQ. A useful feature to apply changes to the stereo field.

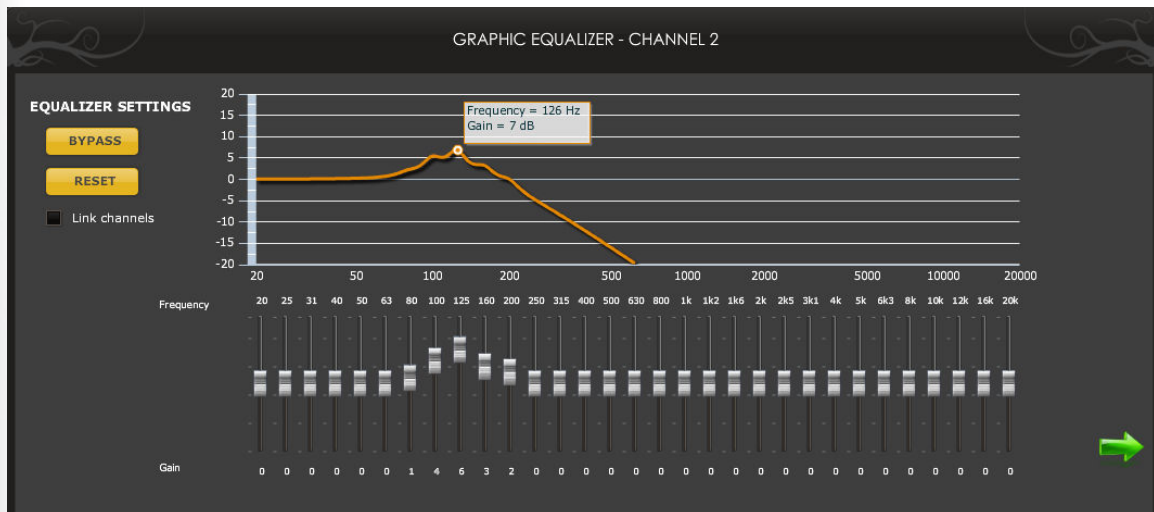

Note: The log graph displays the combined effect of low pass filter, equalization and high pass filtering.

3.1.4 Parametric Equalizer (Available in 2way PEQ, 4way PEQ versions)

- EQ band selection: Select one of the 6 x Parametric equalizers
- Filter type: Select between Peak, Low Shelf, High Shelf
- Bypass: Disables the equalization but doesn't reset the settings. A handy tool to check the influence of equalization on your system without resetting to zero. Note that the bypass button is per-band Bypass (not overall).

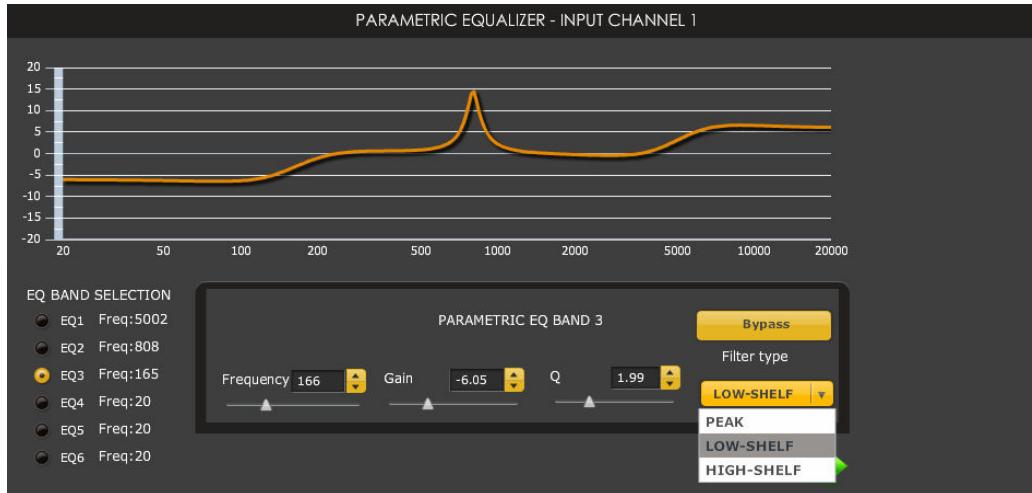

3.1.5 Matrix mixer controls (Available in Mixer plug-in only)

A matrix mixer object allows a set of inputs to be mixed to a set of outputs. In the MiniDSP case, there are 2 inputs (rows) and 4 outputs (columns). By default, Input 1 goes to Output 1&3, while input 2 goes to channel 2&4.



If for example you would like to mix input 2 to output 4, increase the volume of this knob, since it represents the crosspoint between Input Row 2 and Output column 4.

3.1.6 Output Controls for Gain, output level, delay and phase (All plug-ins)

The output section will allow control of time alignment (delay), phase and gain. See below typical screen shot of the interface.

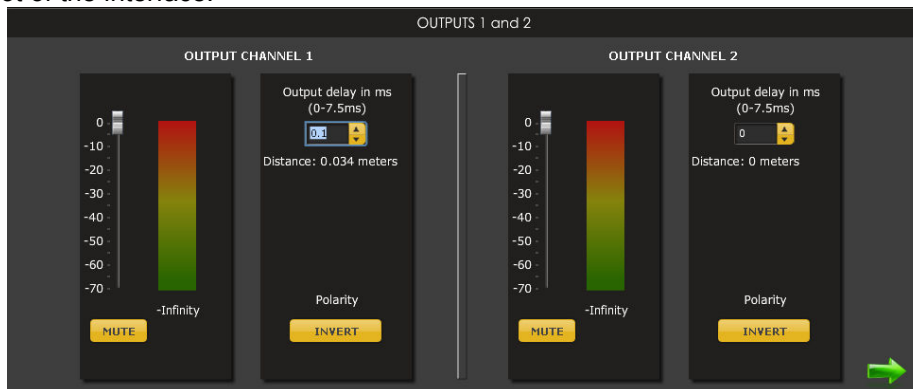

3.1.7 Advanced Plug-in features

For those of you wishing to experiment with your custom filter programming, miniDSP provides an easy interface for custom biquad programming. A lot of readily available information can be found online and the reader shouldn't expect this user manual to provide the basics about biquad programming. For more info, google "Biquad filters", "digital filters", "eq cookbook"...

The advantage of the Advanced mode remains the flexibility miniDSP provides in allowing you to build any custom filter (e.g. cascade filter, Linkwitz transform, high order filters...etc) with a simple programming user interface as shown below.

How to use the advanced mode:

First and foremost, you will need understand that biquad coefficients can represent a wide range of filters (e.g. LPF/HPF/PEQ/high shelv...etc). Using the biquad calculator, you can easily calculate these coefficients without the need of any external software. Building a cascaded filter configuration is a child's play! ☺

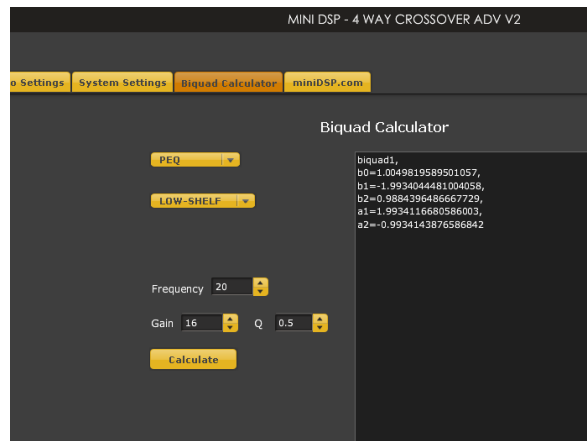

PEQ interface for basic vs Advanced mode:

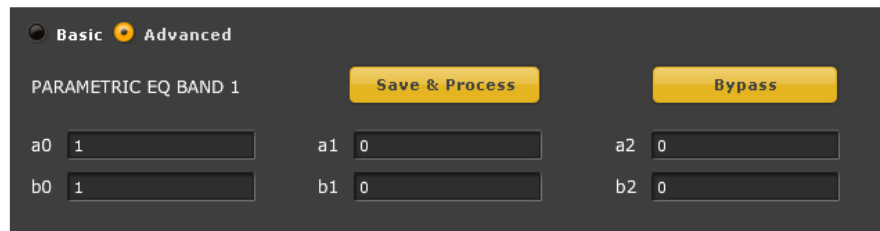
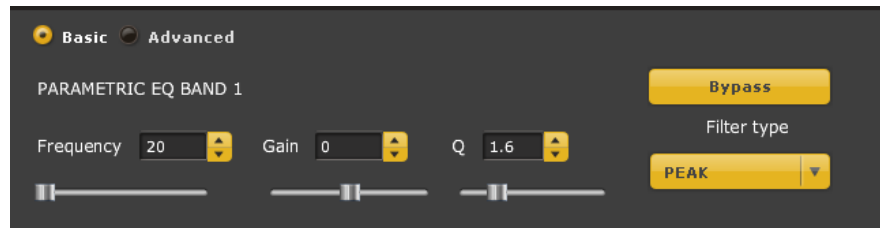

Filter interface for basic vs Advanced mode:

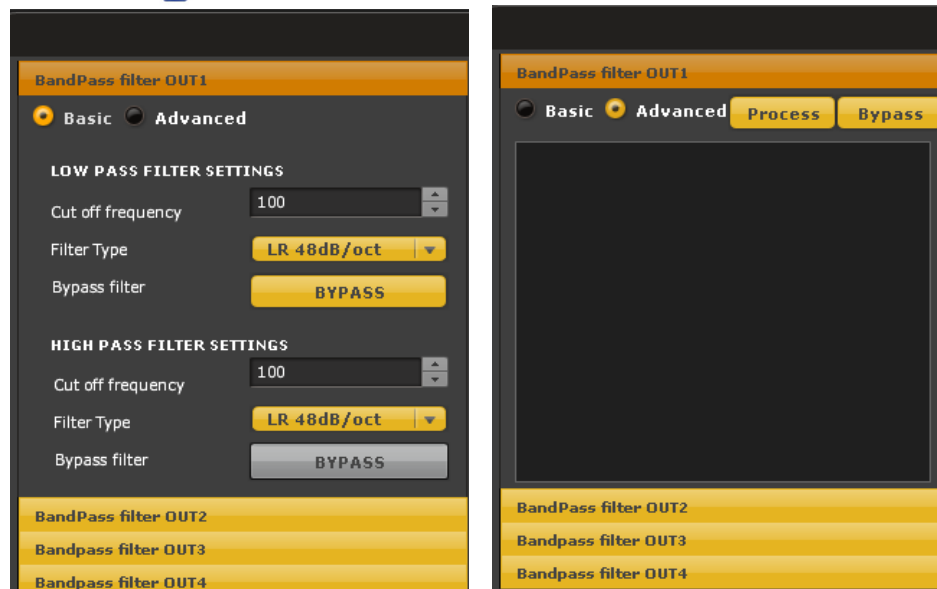

Note: In the filter mode, the software interface expects the 8 biquads to be filled in such format:

```

biquad1,
b0=0.000042324375459811486,
b1=0.00008464875091962297,
b2=0.000042324375459811486,
a1=1.975933280159253,
a2=-0.9761025776610925,
biquad2,
b0=0.000042324375459811486,
b1=0.00008464875091962297,
b2=0.000042324375459811486,
a1=1.975933280159253,
a2=-0.9761025776610925,
.
.
.
.
biquad8,
b0=0.000042324375459811486,
b1=0.00008464875091962297,
b2=0.000042324375459811486,
a1=1.975933280159253,
a2=-0.9761025776610925
    
```

3.1.8 Room EQ Wizard (REW) integration (Advanced software only)

Also available uniquely for the Advanced biquad product series is the integration with REW software. By combining a measurement software with our miniDSP kits, it basically allows custom biquad filters generated by the AutoEQ function of REW to be inputted inside the miniDSP software. For more information, please consult the REW software user manual and EQ device section.

3.2 System settings (Available for all plug-ins)

The system settings page contains the following controls.

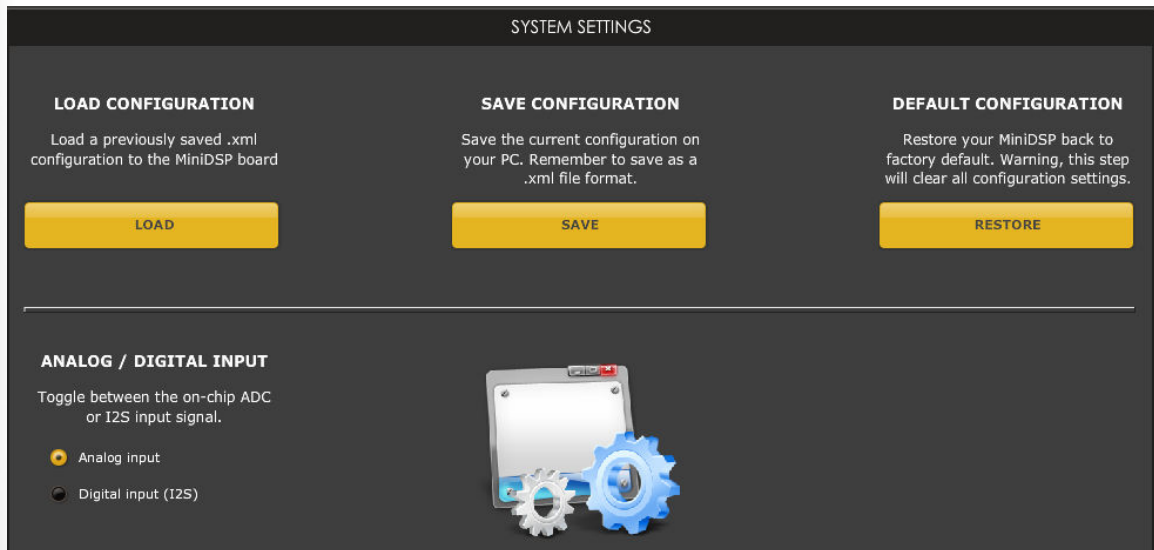

3.2.1 Load configuration:

Use this feature to load a previously saved configuration. The file must be as .xml format and previously saved from this plug-in. For complexity reasons, inter-plug-in compatibility is not available.

3.2.2 Save configuration

Click on this button to save your audio settings configuration. The following dialog box allows you to save the file anywhere on your PC as a .xml format.

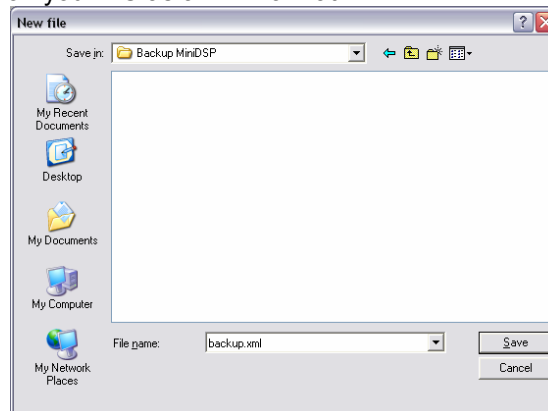

Warning: Remember to save the file as .xml file extension. (e.g. file saved as backup.xml) Otherwise the software will not recognize the file at restore.

3.2.3 Restore

Clicking on this button will restore the board back to factory default. All settings will be lost during this process.



Troubleshooting miniDSP 2x4

The following symptoms were found to be the most likely cause of issues.

Item#	Symptoms	Troubleshooting recommendation	If not solved go to item
1	No audio on outputs	<ul style="list-style-type: none">- Make sure that audio signal is shown on the RMS input meters.- Double check that input & output mute buttons are not greyed out (mute ON)- Confirm that master mute is disabled	3
2	No audio on RMS input meters	<ul style="list-style-type: none">- Check your connectivity- Double check the strength of your input signal.- Confirm that master mute is disabled	10
3	Audio on input RMS meters but no audio on outputs	<ul style="list-style-type: none">- Make sure the matrix mixer is set to send audio to the output channels in a mixer plug-in- Check the output mute status for each channel	10
4	Cannot reload configuration	<ul style="list-style-type: none">- Confirm the file format of your file (.xml)- Confirm the version of the file	10
5	Cannot connect to the board	<ul style="list-style-type: none">- If using external DC supply, try connecting the board with USB power only	10
6	Cannot install software	<ul style="list-style-type: none">- Confirm that you installed the required frameworks (Adobe Air/ Microsoft .net / SP2 XP)	10
10	Problem unsolved by above suggestions	<ul style="list-style-type: none">- Have a look at our forums to see if someone else already had this issue.- Send us an email (info@minidsp.com) with a clear explanation of the symptoms and descriptions of the troubleshooting steps you already performed	n/a